



ALPINE FIRE PROTECTION DISTRICT

FARMERS MARKET and COOKING BOOTHS for VENDORS

All Cooking Booths and Vendors using open flame shall comply with the
2022 California Fire Code

Chapter 31 Tent and other Membrane Structures

3103.8.2 Location - Tents or membrane structures shall not be within 20' feet of lot lines, buildings, or other tents or membrane structures, parked vehicles or internal combustion engines. For the purpose of determining required distances, support ropes and guy wires shall be considered as part of the temporary membrane structure or tent.

3107.4 Open or Exposed Flame. Open flame or other devices emitting flame, fire or heat or any flammable or combustible liquids, gas, charcoal or other cooking device or any other unapproved devices shall not be permitted inside or located within 20' feet of the tent or membrane structures while open to the public unless approved by the fire code official.

3107.12.5 Cooking Tents. Tents with sidewalls or drops where cooking is performed shall be separated from other tents or membrane structures by a minimum of 20' feet.

3107.12.6 Outdoor Cooking. Outdoor cooking that produces sparks or grease laden vapors shall not be performed from other tents or membrane structures by a minimum of 20' feet.

See Table 6104.3 For Containers 500 gallons or less distances. Portable LP-gas containers with a capacity of 500 gallons or less shall have a minimum separation between the container and structure not less than 10' feet.

3107.13.3 Protection and Security. Portable LP-gas containers, piping, valves and fittings which are located outside and are being used to fuel equipment inside a tent or membrane structure shall be adequately protected to prevent tampering, damage by vehicles or other hazards and shall be located in an approved location. Portable LP-gas containers shall be securely fastened in place to prevent unauthorized movement.

1364 Tavern Road Alpine, Ca. 91901-3831 Business: (619) 445-2635 Fax: (619) 445- 2634

We are a public safety organization of dedicated professionals whose mission it is to:
Save Lives, Protect Property and the Environment, Serve the Community.
www.alpinefire.org

FARMERS VENDOR AND COOKING BOOTH LOCATIONS

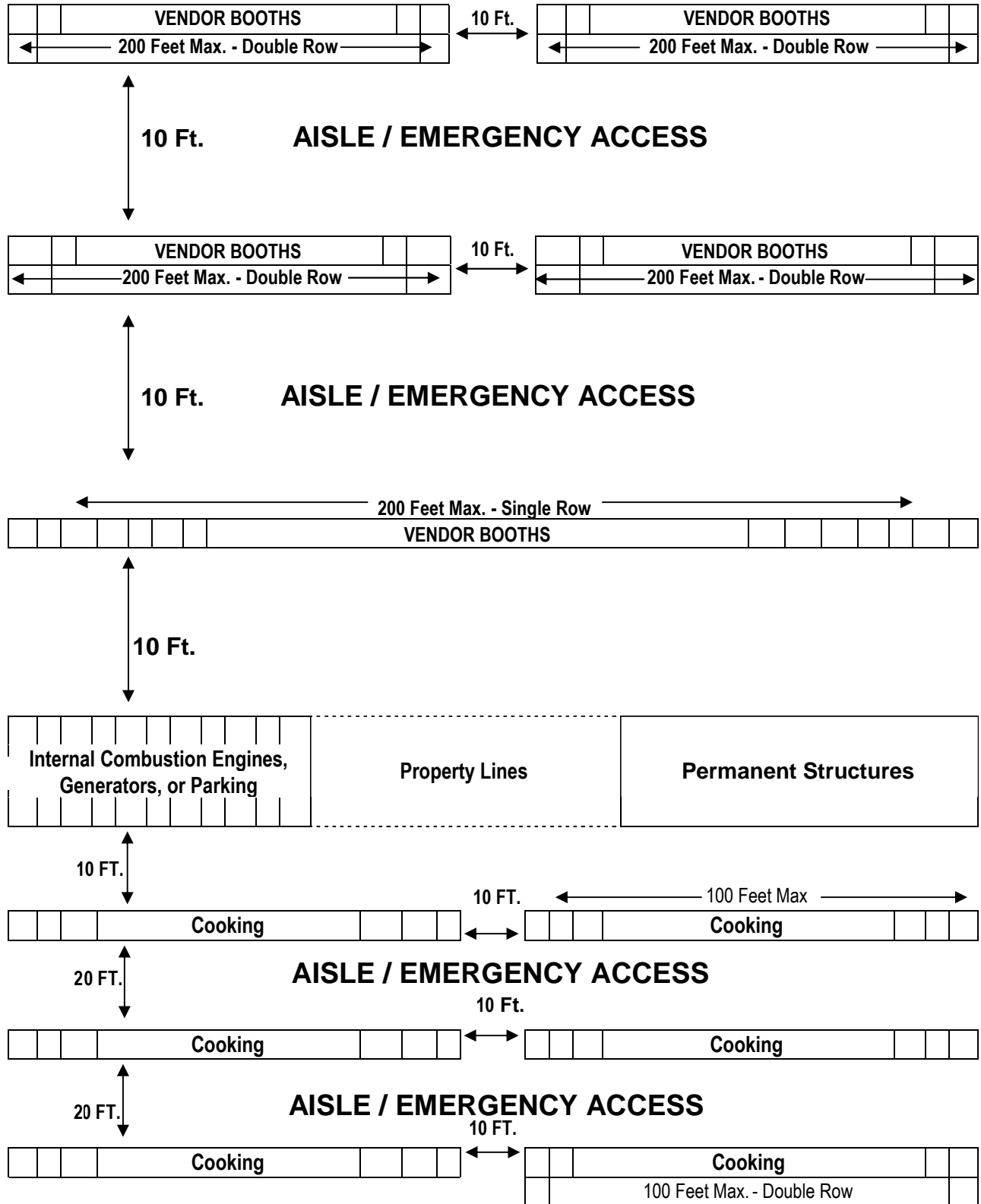

*Note: Cooking Booths are limited to single rows only.
Back-to-back rows are not permitted. Maximum length of row is 100 feet.*

Festival Cooking Booth

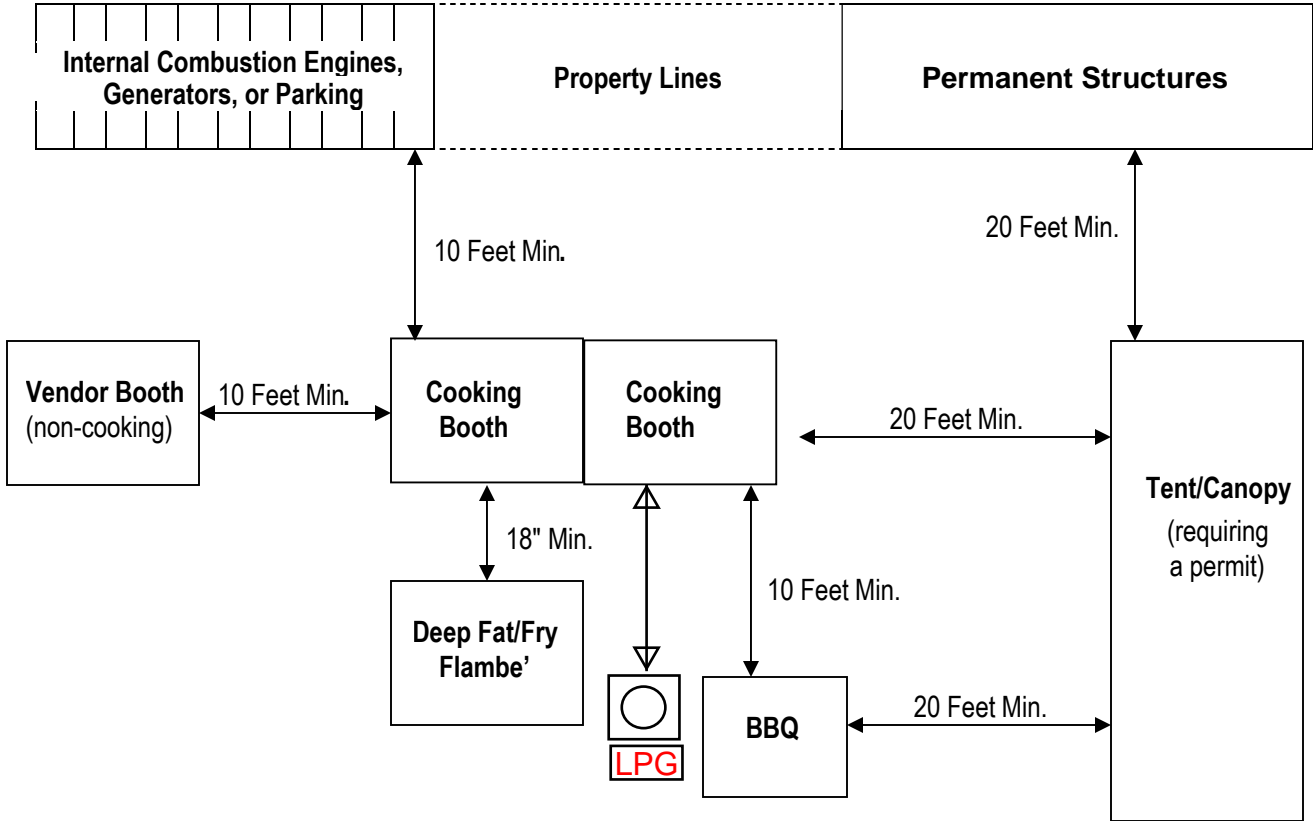
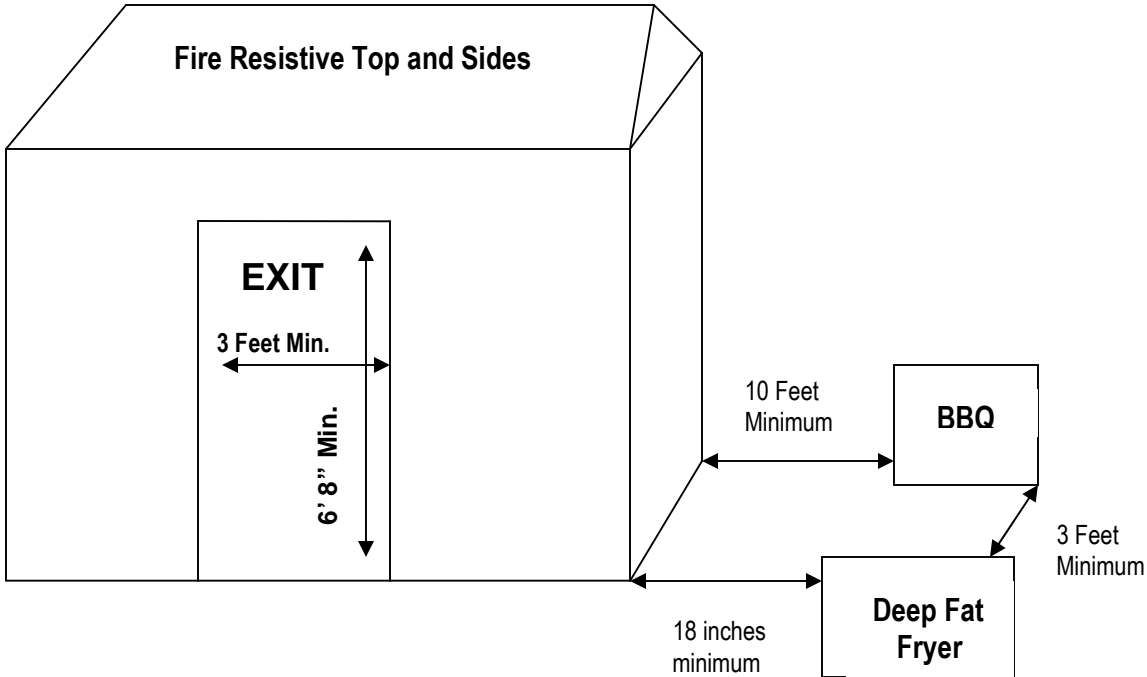

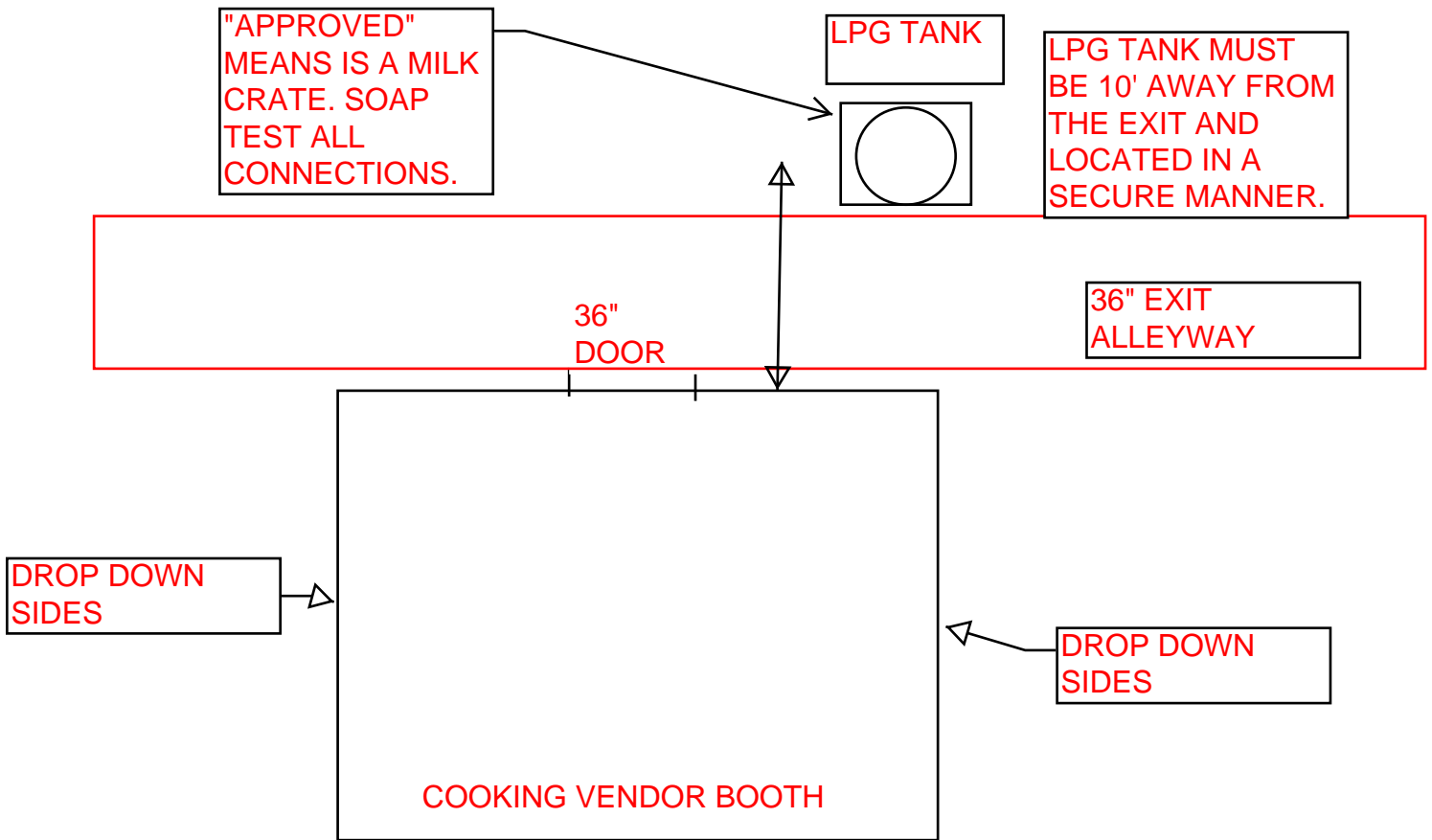

APPROVED COOKING BOOTHS SHALL BEAR THE INHERENTLY FLAME RETARDANT SEAL AND MUST BE CURRENT AS PER THE MANUFACTURES LISTING. ALL COOKING SURFACES AND TABLES SHALL BE NON-COMBUSTIBLE CONSTRUCTION. ANY TABLE WITH AN OPEN FLAME SHALL BE APPROVED AND NON COMBUSTIBLE. WARMING CHAFERS WITH "STENO" SHALL HAVE NON FLAMMABLE FABRIC TABLE CLOTHS AND NON COMBUSTIBLE ITEMS ON THAT TABLE.

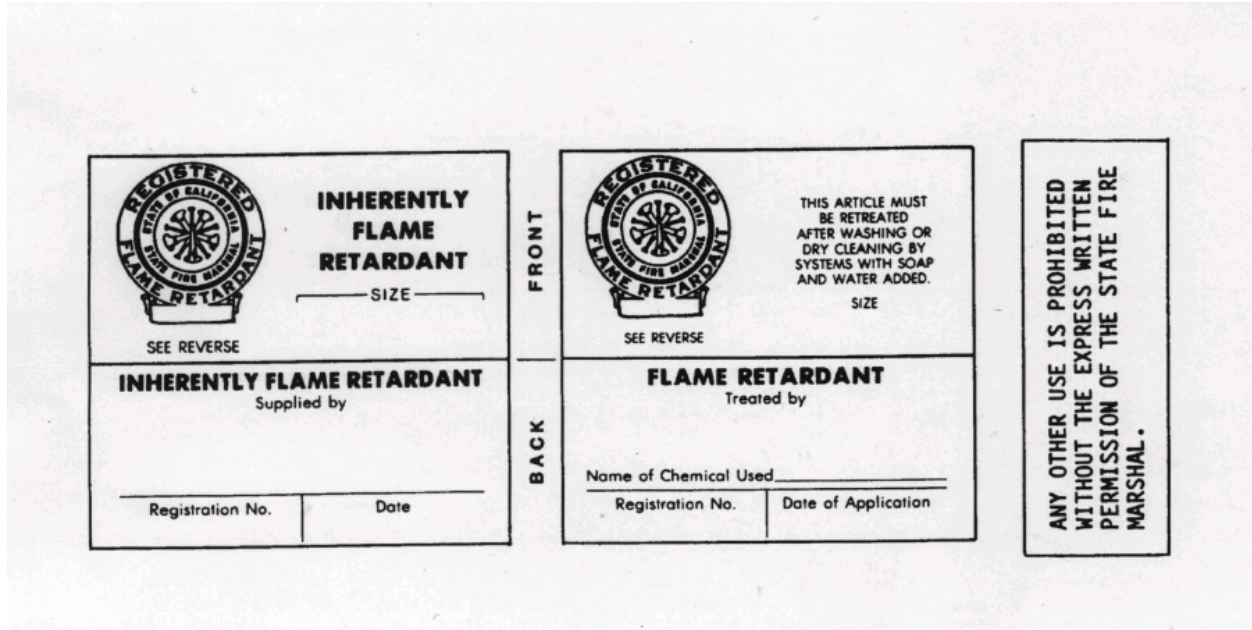



**ALPINE FIRE
PROTECTION DISTRICT
(619) 445-2635 •
FAX (619)-445-2634**

**RESPONSIBLE VENDOR FORM FOR
OUTDOOR COOKING BOOTHS**

Name of Vendor: _____

Mailing Address: _____

Telephone Number: _____

Type of Outdoor Cooking Booth: _____

Date(s) of Function: _____

Location of Function: _____

I, _____ (*Print Name*) hereby represent and warrant that I am the authorized agent of _____ (*Print Name of Vendor*), with the authority to act on its behalf.

On behalf of said vendor, I have read and understood the Fire Department's Regulations for Outdoor Cooking Booths ("Regulations"), and I agree to comply with the Regulations at the location and on the date(s) specified above.

I understand and agree that the Fire Marshal (and/or representative thereof) may inspect said vendor's cooking booth at any time to enforce the Regulations.

I further understand and agree that said vendor shall be held liable for any and all fees and costs related to violations of the Regulations, as determined by the Fire Marshal, in the exercise of his/her sole discretion.

READ, UNDERSTOOD, AND AGREED:

Signature

Date

Name and Title

Please return this completed form to: ALPINE FIRE PROTECTION DISTRICT

1364 TAVERN ROAD
ALPINE, CA. 91901